

HIGHLY EFFICIENT SOFT MOUNTED WASHER EXTRACTORS

**FX
RANGE**

FX180	FX240	FX280
18KG 39LB	24KG 55LB	28KG 70LB



FEATURES

- Freestanding, high spin
- 400 G extraction speed (FX180, FX240)
- Stainless steel top and anthracite front and side panel
- Stainless steel drum and tub
- Cascade Drum
- Patented soap hopper
- Liquid soap connection
- High capacity water inlets (FX280)
- Large drain valve (Ø 76 mm)
- Easy access to all vital parts from the front
- Large door opening for easy loading & unloading

OPTIONS

- Coin operated
- Stainless steel cabinet
- USB + RS485 plug (XControl FLEX / XControl FLEX Plus)
- Liquid soap pumps
- Water recovery kit
- Steam heating version
- 3rd water inlet
- High capacity water inlets (FX180, FX240)

CONTROL OPTIONS

- XControl (VEND only) - easy-to-use microprocessor
- XControl Plus (OPL only) - fully programmable
- XControl FLEX (OPL/Vend)
 - ▮ 7", full color touch screen display
 - ▮ User-friendly screen with operating instructions built in as part of the control
 - ▮ Complete control content available in 34 languages
 - ▮ 15 wash cycles for OPL, 10 for Vend
 - ▮ 11 easy-to-understand cycle modifiers
 - ▮ Machine programming & firmware updates through cloud



INTUITIVE TOUCH
SCREEN CONTROL



LARGE DOOR
OPENING



LOW WATER
AND ENERGY
CONSUMPTION

GET AHEAD IN LAUNDRY

TYPE		FX180	FX240	FX280
INNERDRUM				
Maximum capacity 1:9	kg	20	27	32
Capacity 1:10	kg	18	24	28
Volume	litres	180	240	280
Diameter	mm	750	750	750
DRUM SPEED				
Wash	rpm	42	42	42
Extraction	rpm	980	980	915
G-FACTOR				
		400	400	350
HEATING				
Electricity (standard)	kW	12 / 18	18	18 / 21,9
Steam	bar	1-8	1-8	1-8
Hot water	°C	90	90	90
Sound pressure level	dB (A)	< 65	< 65	< 65
Water valves connection	BSP	3/4"	3/4"	3/4"
Water pressure	kPa	100-800	100-800	100-800
Rec. water pressure	kPa	300-500	300-500	300-500
Water inlet	l/min	20	20	20-50
Drain valve	outer Ø mm	76	76	76
Flow amount with drain valve	l/min	210	210	210
Steam valve connection	BSP	1/2"	1/2"	1/2"
Steam pressure	kPa	100-800	100-800	100-800
DIMENSIONS				
Size H×W×D	mm	1430×970×970	1430×970×1105	1430×970×1185
Net weight	kg	380	430	495
TRANSPORT DATA				
Packed H×W×D	mm	1550×1025×1015	1550×1025×1150	1550×1025×1225
Gross weight	kg	395	450	515

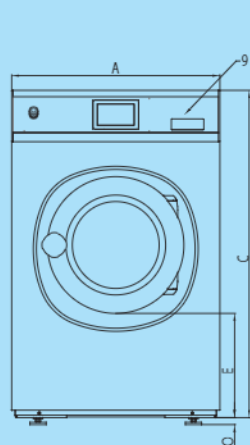

Front side

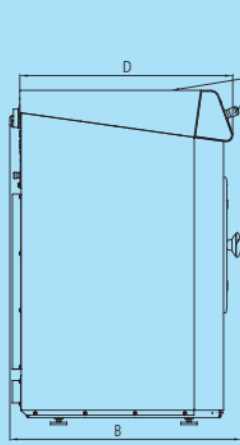

Left side

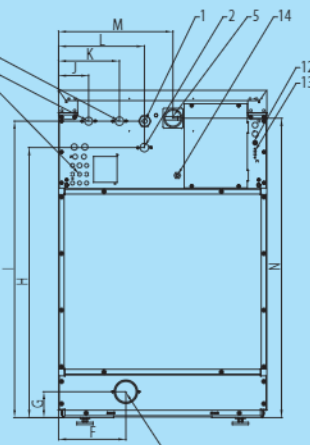

Rear side

- 1 Electrical connection
- 2 Hot water
- 3 Cold water hard
- 4 Cold water soft
- 5 Main switch
- 6 Liquid soap connection
- 7 Drain
- 8 Soap dispenser
- 9 Control panel
- 10 Button CENTRALSTOP
- 11 Door opening Ø 460mm
- 12 Fuses
- 13 USB port
- 14 Electrical connection to liquid soap pumps

DIMENSIONS

	A	B	C	D	E	F	G	H	I	J	K	L	M	N	O
FX180	970	970	1430	906	477	270	108,5	1215	1297,5	102,5	208	293	610	1315	24
FX240	970	1105	1430	1041	477	270	108,5	1215	1297,5	102,5	208	293	610	1315	24
FX280	970	1185	1430	1116	477	270	108,5	1215	1305	102,5	208	293	610	1315	24
	width	depth	height												



The Primus preserves the right to change the machines and the specification in this leaflet at any time, without prior notice. Details and photographs are only for information and never binding.
www.primuslaundry.com



Primus by Alliance Laundry Systems